



Royce Interface Level Analyzer and Sensors

(8182)63-90-72
+7(7172)727-132
(4722)40-23-64
(4832)59-03-52
(423)249-28-31
(844)278-03-48
(8172)26-41-59
(473)204-51-73
(343)384-55-89
(4932)77-34-06
(3412)26-03-58
(843)206-01-48

(4012)72-03-81
(4842)92-23-67
(3842)65-04-62
(8332)68-02-04
(861)203-40-90
(391)204-63-61
(4712)77-13-04
(4742)52-20-81
(3519)55-03-13
(495)268-04-70
(8152)59-64-93
(8552)20-53-41

(831)429-08-12
(3843)20-46-81
(383)227-86-73
(4862)44-53-42
(3532)37-68-04
(8412)22-31-16
(342)205-81-47
- - (863)308-18-15
(4912)46-61-64
(846)206-03-16
- (812)309-46-40
(845)249-38-78

(4812)29-41-54
(862)225-72-31
(8652)20-65-13
(4822)63-31-35
(3822)98-41-53
(4872)74-02-29
(3452)66-21-18
(8422)24-23-59
(347)229-48-12
(351)202-03-61
(8202)49-02-64
(4852)69-52-93

: rcy@nt-rt.ru | <http://royce.nt-rt.ru>

Model 2511A Interface Level Analyzer

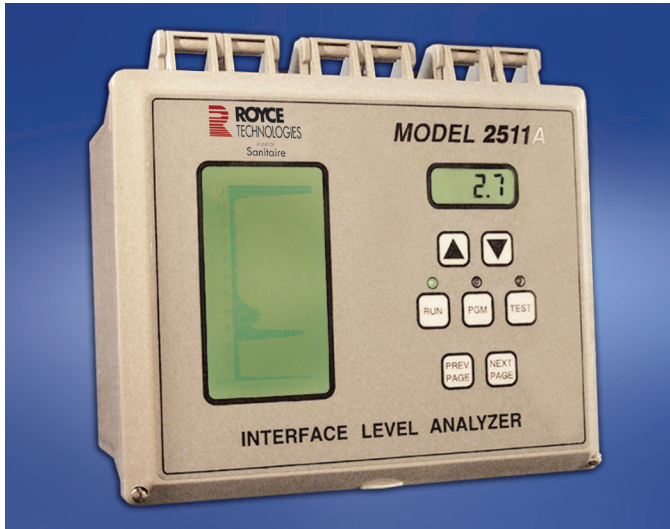

MODEL 2511A ANALYZER

The Royce Interface Level Analyzer makes it possible to reliably monitor and control the solid/liquid interfaces in settling tanks and clarifiers regardless of the size of the plant, process or budgetary constraints. The analyzer measures and outputs clarity as well.

The Royce Interface Level Analyzer uses an ultrasonic ranging technique to measure the depth of interfaces within the tank. The 25 series sensors are available in polyurethane for standard applications and Kynar for high temperature or chemical applications. The sensor is mounted just below the surface of the water. Royce offers a hinged bracket sensor mounting option that accommodates surface skimmer passage automatically with the rotation of the rake.

The Model 2511A is capable of having the ultrasonic speed of sound signal from its transducers changed by the user in applications where liquid mediums other than water are in use. It also has four setpoint relays which can each be used as either a "high" or "low" setpoint. A serial output is available for the purpose of tying a number of the units to a central process control computer.

APPLICATIONS

- Waste Treatment Clarifiers; Primaries, Secondaries, Gravity Thickeners
- Petroleum/Asphalt Separation Tanks
- Pulp & Paper Liquor Tanks
- Potable Water Clarifiers
- Raw Water Clarifiers
- Lamella Clarifiers
- Precious Metal Separators
- Any Tank with a Liquid/Solid Interface
- Mining Clarifiers
- Brine Tanks
- Slurry Tanks
- Settling Tanks

FEATURES

- Measures both interface and Clarity
- No Moving parts, no maintenance, no recalibration required
- Surface skimmer friendly
- Microprocessor based electronics
- Back-Lit LCD displays
- Full featured set point relays available
- Simple user friendly menu driven programming
- Numerical and graphical displays

MODEL 2511A

The graphical display on the Model 2511A provides at least three very useful functions:

1. During start up, the customer is instructed, step by step, through the programming parameters which make the analyzer operable
2. Profiles the entire liquid column of the tank, showing all solids interfaces. This will continually update stored information as sounding data is revised
3. A trend of the interface level of interest, covering up to the last 24 hours, will continually be updated and available to the graphical display with the press of a button.

The microprocessor in the instrument is also used to provide a flexible, convenient customer interface with simplified setup, calibration, and troubleshooting procedures.

The displays, setpoint relays, and remote outputs are all under direct microprocessor control. As a result, data is scaled easily to suit the specific needs of the customer.

Separate back lit, digital and graphical displays provide the numerical location of the desired solids interface, as well as a profile of the entire clarifier in real time. This profile visually depicts each interface in the clarifier and labels their individual levels. The amount of ultrasonic energy required for the reading is also shown on the graphical display; this informs the user of the relative signal absorption present in the clarifier at the time of the reading.

The fiberglass NEMA 4X instrument enclosure can be mounted on a vertical or horizontal handrail, or a wall. The ultrasonic sensor with 25 feet of cable mounts on either a fixed support or a swing out bracket. A number of different sensor designs are available for applications in harsh environment clarifiers and washers.

MODEL 2511A SPECIFICATIONS

Tank Level Ranges:

1 to 99 feet, in feet, meters, % depth

Dead Zones:

1 foot from sensor and 2 inches above tank bottom

Level Resolution:

0.1 feet to 25' depth
0.2 feet to 50' depth
0.3 feet to 75' depth
0.4 Feet to 100' depth

Stability:

0.1% per degree centigrade

Sensor Ambient Conditions:

Temperature, -30 to 80°C
High Temperature Sensor, -30 to 105°C

Instrument Ambient Conditions:

Temperature, -10 to 50°C
with heater, -40 to 50°C
Relative Humidity, 5 to 100%, non-condensing

Power Requirements:

115/230 VAC \pm 15%, 50/60 HZ

Enclosures:

NEMA 4X

Cabling Limitations:

Sensor to Transceiver distance, 75 feet, maximum
Transceiver to instrument distance, 750 feet, shielded cable

Outputs:

4 - 20 mA isolated, can be scaled to any range
4 - 20 mA isolated, relative clarity of top four feet of tank
Digital Serial Interface either RS 232 or RS 485.

Relays:

Up to 4 Standard setpoint relays with programmable hysteresis form C rated 250 VAC at 6 Amps resistive

Additional Features:

Microprocessor controlled
Programmable digital display
Self test and automatic calibration
Help Screens and graphic display
Compensation for nonstandard speed of sound

HOW IT WORKS

The Series 25 Sensor is mounted so that it is suspended just below the surface of the tank liquid. (See SENSOR AND TRANSCIEVER MOUNTING).

The dual crystal sensor, Model 25DN, uses one transducer to send and one transducer to receive. This gives the highest resolution and minimum dead band. All the single crystal sensors operate by both transmitting and receiving. In both cases, the crystal(s) operate under the analyzer's control emitting a directional burst of ultrasonic energy towards the bottom of the tank.

Energy reflected back and captured by the sensor is amplified by the receiver circuitry and digitized by the analyzer. In this way, the system builds a complete "tank profile" in the processor's memory which contains the magnitude of the reflected signal for every 1/10th foot increment in depth.

This profile is created on an averaging basis so that the incidental reflections from passing debris or a passing skimmer will not cause false readings. The analyzer interprets these arithmetic profiles to determine the position of all the layers in the tank. Once the instrument's software identifies the interface of interest (programmed by the operator during setup) the depth of that interface is digitally displayed on the numerical LCD display.

At the same time, the graphical display is updated to show the profile of the entire tank depth. In these profiles, a peak in the reflected energy indicates the position of an interface, between density layers. The size of each peak is a function of the relative density of the layers. Thus the lighter "fluff" layers, which might be suspended above the main blanket, will appear as smaller (shorter), often broader peaks on the profile. In any case, the position of all the interfaces in the tank are detectable.

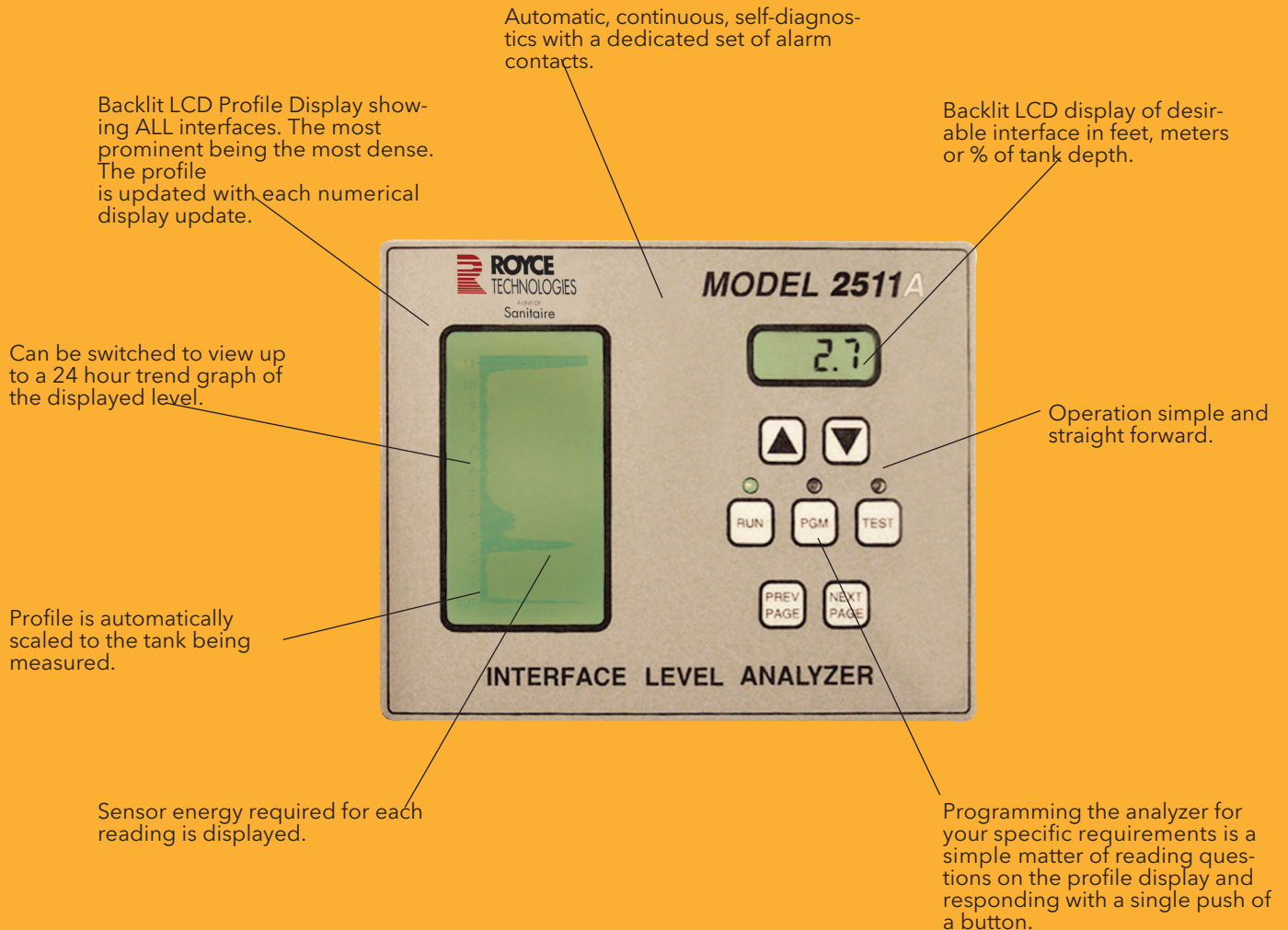

Ultrasonic Sensors for the 2511A Interface Level Analyzers



MODEL 25DN

The standard ultrasonic, dual crystal sensor used with the 2511A Interface Level Analyzer for all normal aqueous, non-chemical conditions, where maximum temperatures do not exceed 175°F (80°C). It incorporates a 3/4" 316 Stainless Steel nipple for customer supplied pipe mounting.

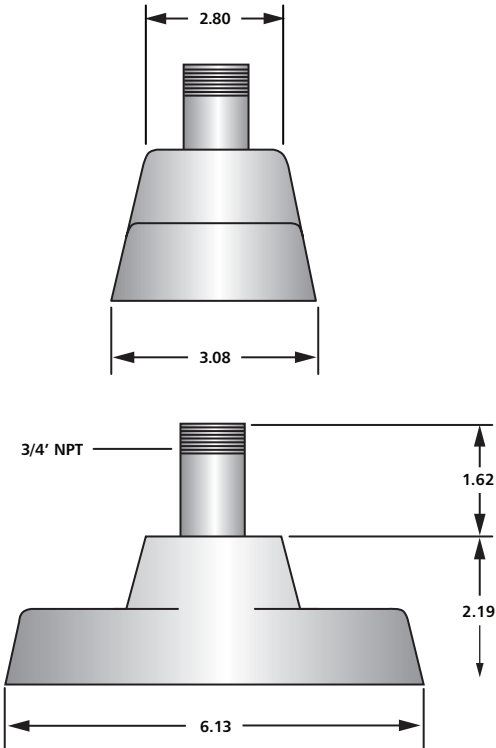

MODEL 25SN

Designed specifically for the Model 2511A analyzer, this economical sensor uses a single crystal to both transmit and receive. Constructed of the same material as the 25DN; it is used in non-chemical applications where the maximum temperatures do not exceed 175°F (80°C). Its physical size allows the sensor to be inserted into a pipe with an I.D. of 3 inches. It incorporates a 3/4" 316 Stainless Steel nipple for customer supplied pipe mounting.

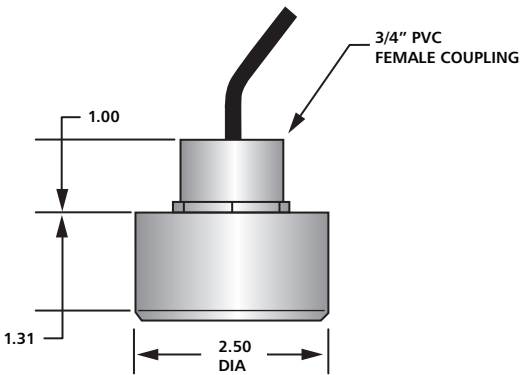



MODEL 25SHE

For generally harsh environment applications, this solid, Kynar sensor is made of chemically inert epoxy. It incorporates a 1" Kynar pipe nipple for customer supplied pipe mounting. All cables are high temperature Teflon jacketed. It can be used in chemical solutions of temperatures to 220°F (105°C).

MODEL 25XP

This optional Class 1 Division 1 rated sensor is constructed of stainless steel for use in locations requiring explosion-proof components and equipment.

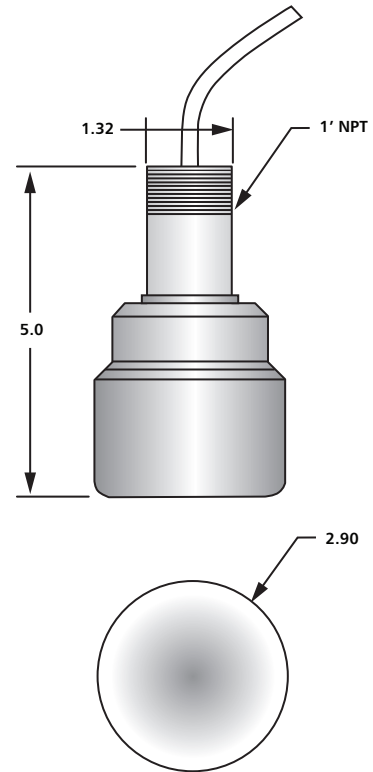

TR-25 & REAR RAIL MOUNT MOUNTED ON HORIZONTAL OR VERTICAL RAIL



TR-25 TRANSCEIVER

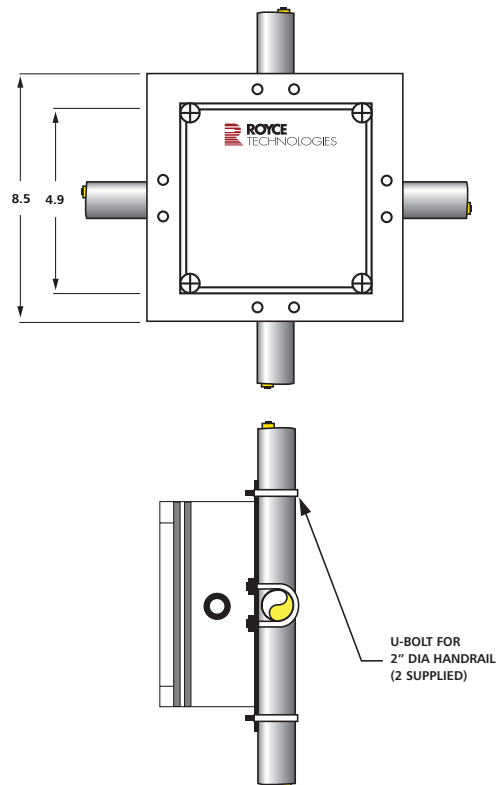

MODEL 2511A ANALYZER SENSOR DIMENSIONS AND MOUNTING

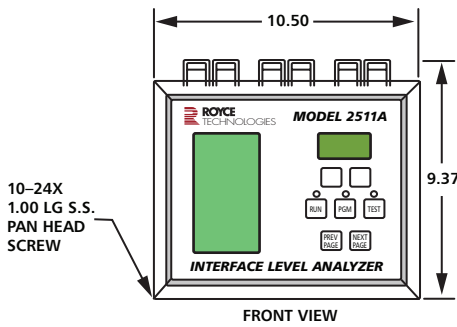

1/4-20 UNC
INSERT, 4 PLCS
0.31 CLEARANCE
DRILL

(4) 1/4-20 X 0.500 LONG
PAN HEAD SCREWS
SUPPLIED WITH
MOUNTING KIT

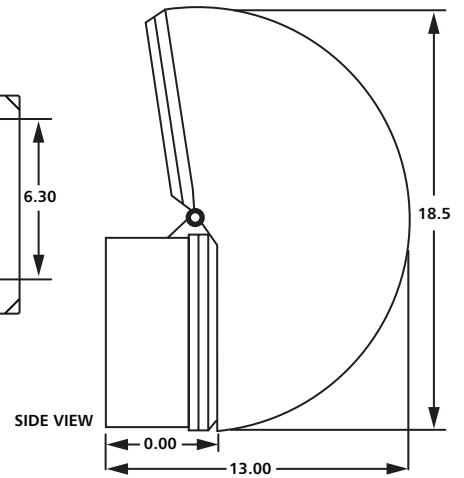
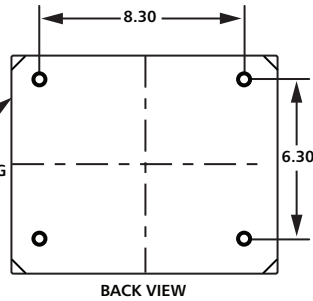

- NOTES:**
1. CONSTRUCTION POLYCARBONATE NEMA 4X ENCLOSURE
 2. APPROXIMATE WEIGHT: 6 LBS.

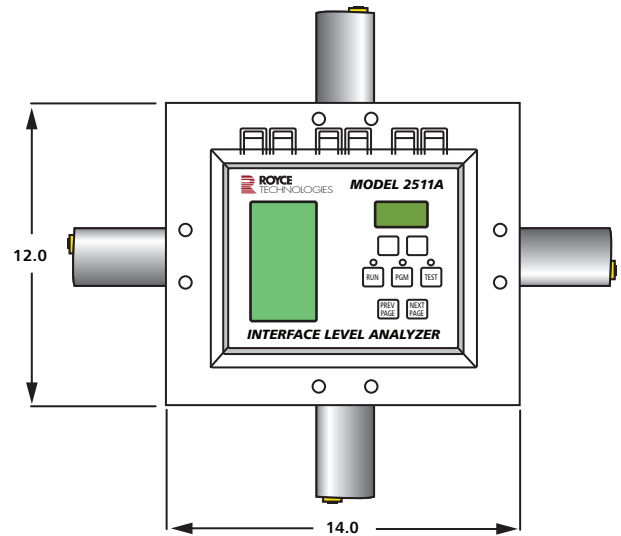
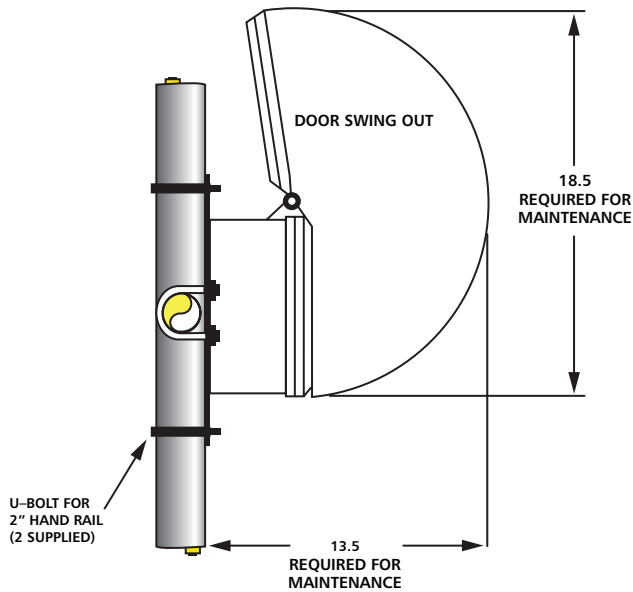

SWING OUT MOUNTING

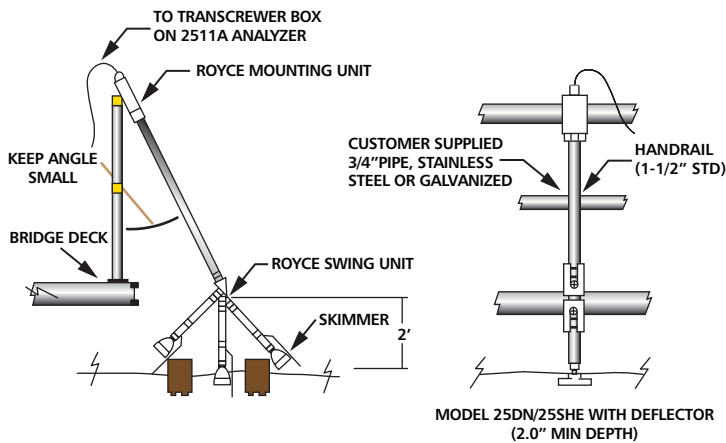

STATIONARY MOUNTING

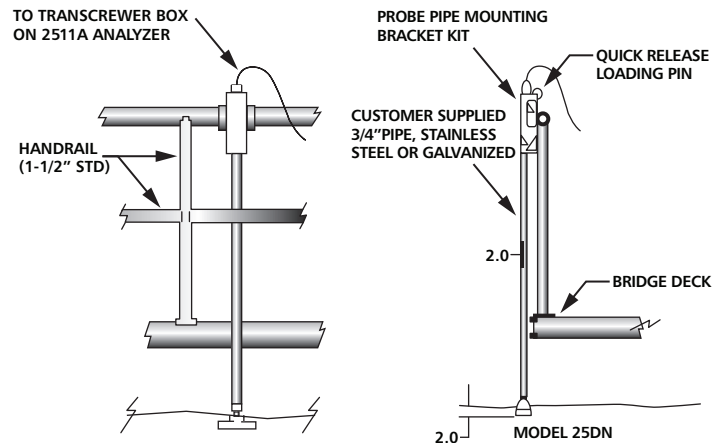

Royce, a Xylem brand, provides high quality monitoring and control instrumentation and sensors specifically designed for municipal and industrial wastewater treatment applications. Recognized throughout the wastewater treatment industry as experts in the biological wastewater treatment process.

MEASUREMENT TECHNOLOGIES BY ROYCE

Dissolved Oxygen Monitoring and Control

- Single and Multi-channel Analyzers
- Bioreactor and Lagoon Systems

Total Suspended Solids Monitoring and Control

- Portable Analyzers
- Single and Multi-channel Analyzers
- Solids density

Interface Level analyzers

- Primary, Secondary and Thickener Analyzers

(8182)63-90-72
+7(7172)727-132
(4722)40-23-64
(4832)59-03-52
(423)249-28-31
(844)278-03-48
(8172)26-41-59
(473)204-51-73
(343)384-55-89
(4932)77-34-06
(3412)26-03-58
(843)206-01-48

(4012)72-03-81
(4842)92-23-67
(3842)65-04-62
(8332)68-02-04
(861)203-40-90
(391)204-63-61
(4712)77-13-04
(4742)52-20-81
(3519)55-03-13
(495)268-04-70
(8152)59-64-93
(8552)20-53-41

(831)429-08-12
(3843)20-46-81
(383)227-86-73
(4862)44-53-42
(3532)37-68-04
(8412)22-31-16
(342)205-81-47
- - (863)308-18-15
(4912)46-61-64
(846)206-03-16
- (812)309-46-40
(845)249-38-78

(4812)29-41-54
(862)225-72-31
(8652)20-65-13
(4822)63-31-35
(3822)98-41-53
(4872)74-02-29
(3452)66-21-18
(8422)24-23-59
(347)229-48-12
(351)202-03-61
(8202)49-02-64
(4852)69-52-93